

# INA Linear Technology

Performance, Quality and Variety without Limits

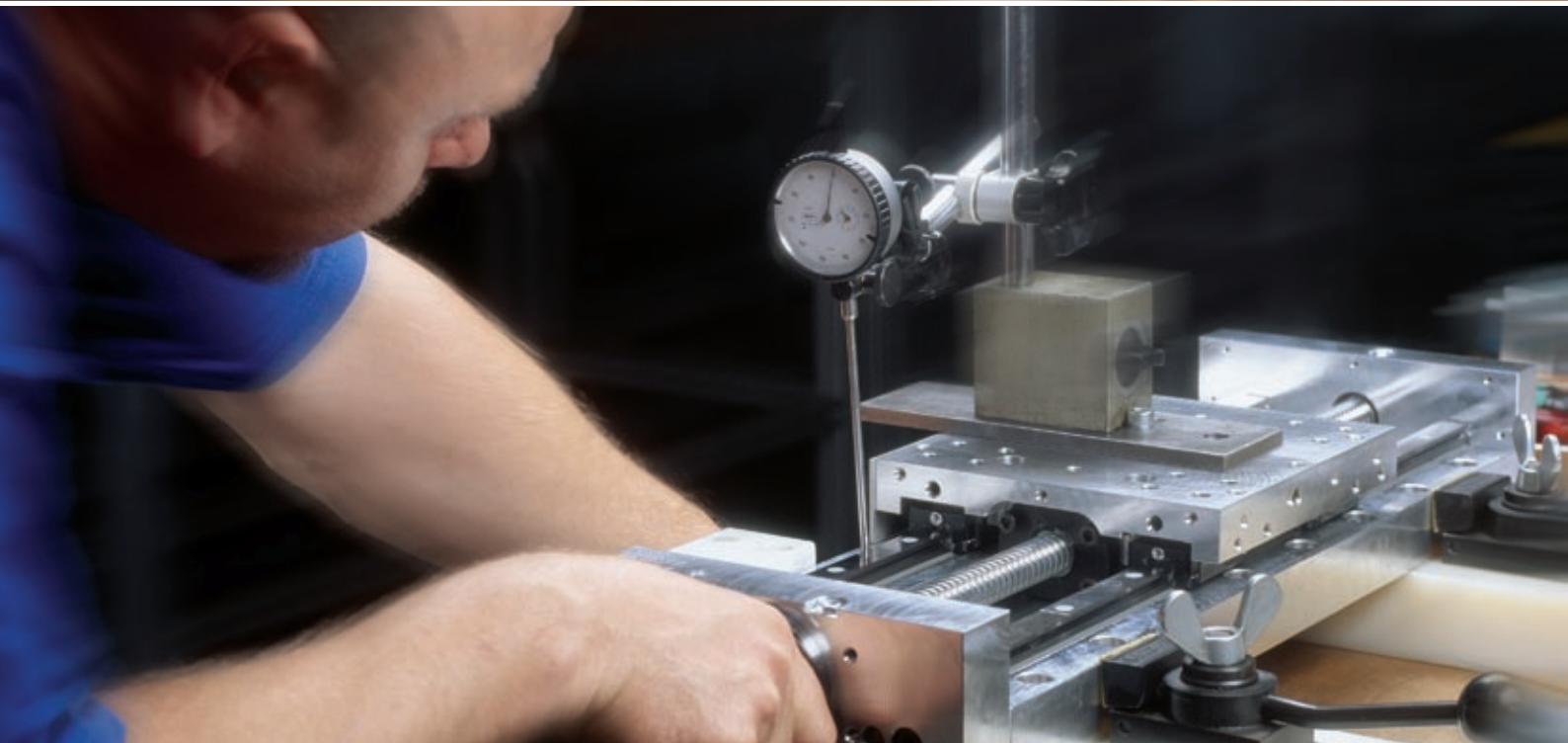

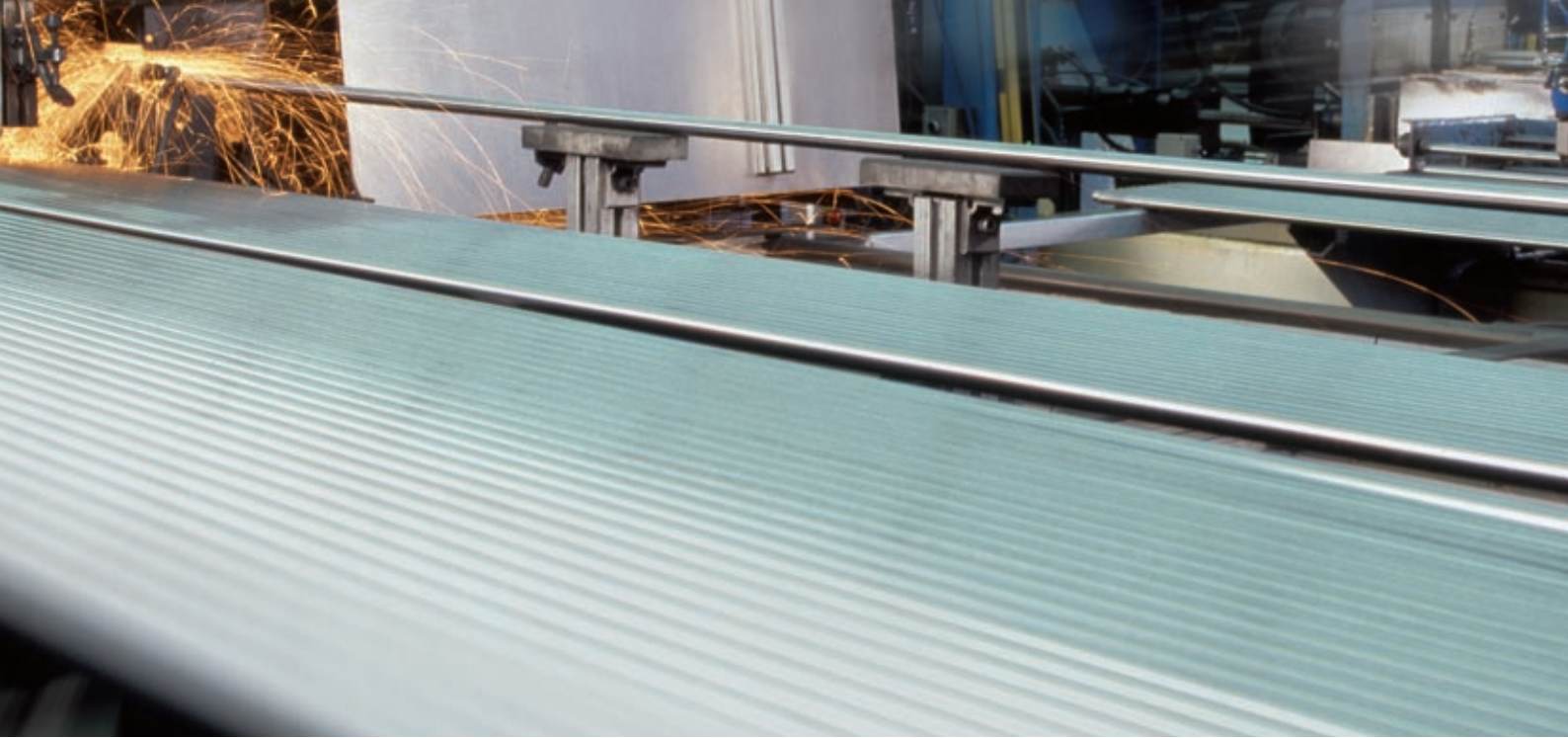

# INA Linear Technology

## Products and System Solutions with a Difference

The Schaeffler Group and its three strong brands, INA, FAG, and LuK is internationally renowned for high-quality rolling bearing technology as well as components and systems for the automotive industry. INA linear guidance systems have been an important part of our product range for more than 50 years. Today, the Schaeffler Group's sophisticated and comprehensive range of linear products is unrivalled in its scope worldwide.

Our linear products are manufactured in Homburg, Germany and in Haguenau, France. Homburg is also the base for development, design, and sales for linear technology for the entire Schaeffler Group. Modern manufacturing facilities in all plants ensure a high level of vertical integration and high quality, all locations are certified to international standards such as ISO/TS 16949 and ISO 9001 and are regularly tested.

Our product range spans from customized shafts with linear ball bearings and monorail guidance systems right up to actuators with drives and control systems. The entire range is based on a modular concept - as a modular system full of good ideas. This system enables us to put together cost-effective solutions with our customers that precisely match the application in question. This is because we don't want to be just suppliers, but also a development partner for our customers. This is how many of our linear guidance systems ultimately started out as solutions for customer requirements.

INA Linear Technology - your partner for cost-efficient solutions in linear technology. Just talk to us.



Competence center and headquarters for Linear Technology in Homburg (Saar) – this location has been the base for the sales department of this product sector for the Schaeffler Group worldwide since 1973



The manufacturing location of Schaeffler France/Technique Linéaire in Haguenau (Alsace) – INA linear products have been manufactured here since 1990

# Linear Guidance System

A Product Range that Leaves Nothing to be Desired







# Monorail Guidance Systems

**Linear recirculating roller bearing and guideway assemblies RUE-E** are robust monorail guidance systems with high load carrying capacity and rigidity. With their smooth, uniform running, high dynamics and wide range of accessories, they are the ideal solution for moving heavy loads with precise linear travel. With two basic designs, INA offers the unique combination of the “full complement” principle and “chain systems” in a single guidance system concept. The integrated lubricant reservoir and an efficient sealing concept ensure long operating life with low maintenance requirements.

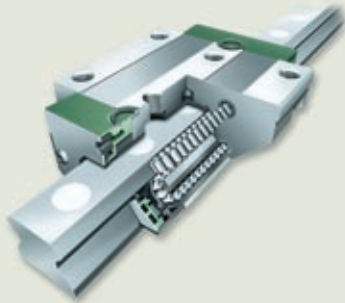

Our most powerful: Full complement linear recirculating roller bearing and guideway assembly with very high load carrying capacity and rigidity, available in sizes 25 to 100, very low stroke pulsation

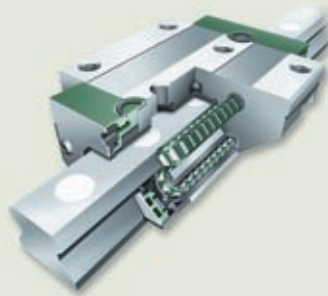

Our quiet one: All technical advantages are the same as the full complement version – separation of the rolling elements via a roller chain in long carriages only

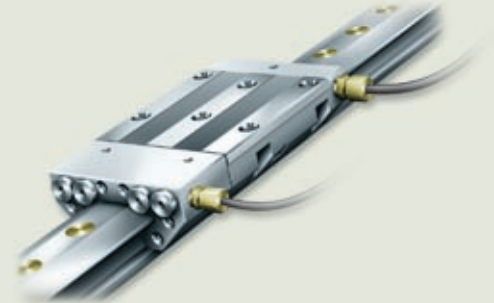

Excellent damping: Hydrostatic compact guide in the design space of a monorail guidance system – integrated hydraulic control system – in size 45

Four-row linear **recirculating ball bearing and guideway assemblies** KUV-B are among INA's classic linear technology products. They are available in basic designs – robust and full complement for high loads, or with quad spacers for low-noise and highly dynamic running. A variant for high-speed applications completes the product range. All designs are almost maintenance-free due to integrated lubricant reservoirs located near the raceways. The largest range of accessories available for monorail guidance system rounds off the range.

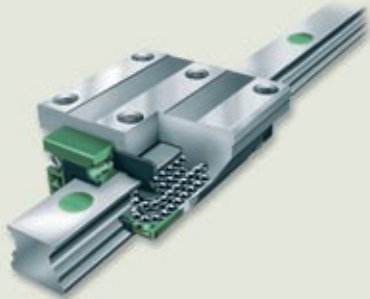

The robust classic: Recirculating unit with full complement of balls in sizes 15 to 55 – high rigidity and precision, up to 6 m/s – largest range of variants for carriages

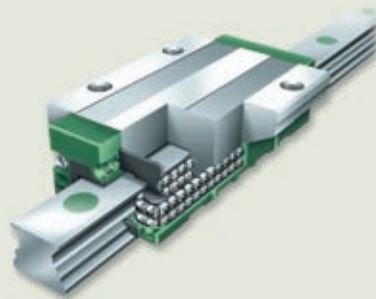

The quiet one: Low running noise and high dynamics in one product – rolling elements are separated by means of quad spacers – sizes 15 to 55

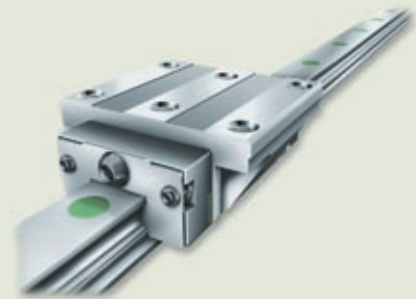

The high-speed design: Up to 10m/s with standard steel rolling elements, without the use of hybrid technology – with high crash safety and precision – size 25

# Accessories for Monorail Guidance Systems

INA monorail guidance systems are based on a modular concept, which means the user can put together the most suitable combination for the particular application. This involves various carriage geometries, integrated toothed guideways, braking and clamping elements, damping carriages, sealing concepts, units for long-term and minimum lubrication, integrated measuring systems, end pieces of metal or plastic and much more. Coatings for protection against corrosion and wear as well as special materials round out the product range.

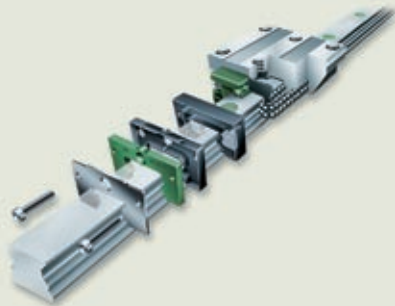

KIT modular system: Graduated system of seal and lubrication elements for monorail guidance systems – can be retrofitted or supplied with the product

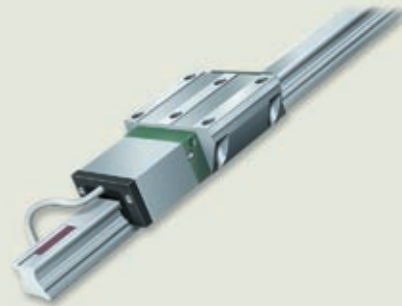

Simple to use: Integrated measuring system with electronic evaluation system for linear recirculating ball bearing and guideway assemblies – incremental or digital – sizes 20 to 45

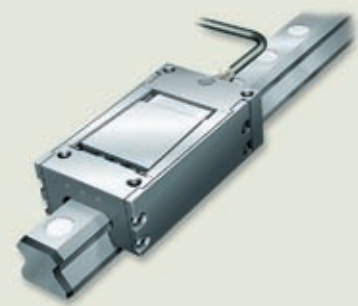

Safety for personnel and machines: Braking and clamping element, can be used as emergency brake in linear motor drives – clearance-free brake shoes



# Miniature Guidance Systems

Miniature linear guidance systems are not just miniature versions of the larger monorail and cage guidance systems, but specially developed and designed systems for small spaces. They have all the technical and economic benefits - high rigidity, compact, smooth running, ready-to-install and maintenance-free depending on the environmental conditions. Their high level of precision and dynamics means that they are especially suitable for applications in clean rooms and in the semi-conductor and medical technology sectors, where rapid positioning with high repeat accuracy is essential.

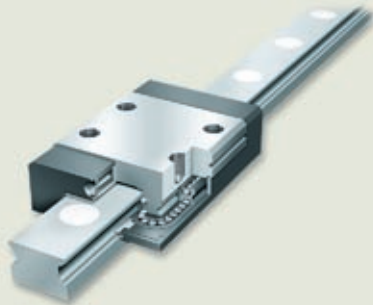

Precision in the smallest of spaces: Four row miniature linear recirculating ball bearing and guideway assembly, sizes 12 and 15 (double row linear recirculating ball bearing and guideway assembly, sizes 5–15)



Extremely smooth running: Miniature carriage unit with cylindrical rollers for limited strokes – sizes 7 to 15 – available with cage positive control if required



Robust solution: Flat cage guidance systems with various cages (rollers/balls/needles) – high load carrying capacity and rigidity for limited strokes

# Shaft Guidance Systems

INA shaft guidance systems are available in our modular system: shafts, linear ball bearings or linear bushings, accessories such as shaft support blocks and guideways, which can be combined to match the technical requirements and the environmental conditions. The basis of these systems are high-precision shafts up to 6 meters long. Linear centers all over the world design the shafts individually according to customer requirements and process them if necessary – with all stages right up to heat treatment. Customer benefit: We can also supply small quantities and have short delivery times.



Shafts made to measure: Solid and hollow shafts of high-quality steel ( $\varnothing$  4 to 80 mm) – individually customized according to customer requirements – tolerance class h6



Saves space: Compact series with drawn outer ring – low radial section height – sizes 6 to 50



Cost-effective and with long life: Linear ball bearings of light series, sizes 12 to 50 – integrated lubricant reservoir – angular adjustment up to  $\pm 30'$

Our range of linear ball bearings is as comprehensive as it is varied. This includes, for example, our cost-efficient and high-precision compact series with drawn outer cup for especially compact designs. You will also find special series for applications that require high load carrying capacity. Both are available in open designs for supported shafts. The product range is extended by the Permaglide® plain bearing series: low maintenance and low noise, insensitive to shocks and with a high static load carrying capacity.



High load ratings: Linear ball bearings in heavy series – effective compensation of misalignments due to four self-aligning segments – sizes 12 to 50



Very good running behavior: Highly rigid shaft guidance system with machined linear ball bearings on a guide-way – hardened, high-precision ground outer ring



Shaft support: Composite rail with aluminum profile and high-precision shaft – large selection available



# Track Roller Guidance Systems

Track roller guidance systems LF in lightweight design are robust products that are insensitive to contamination and which have become standard in many sectors of industry. They operate with low noise, low friction and without stick-slip at high speeds up to 10 m/s. They fulfill the requirements of handling systems to an exceptional standard if long travel distances with constant, low resistance to displacement are required. Here too, we offer the customer-friendly modular system that is typical for INA.

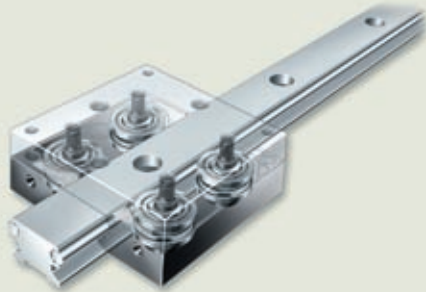

Reliable and lightweight: Track roller guidance system for straight movements in lightweight design – up to 10m/s – low maintenance – a cost-effective solution



Fast cornering: Bogie carriage for track roller guidance systems on curved and straight guideways – with all the advantages of a standard track roller guidance system



Profiled track roller (locating bearing): Double row angular contact ball bearing with profiled outer ring – maintenance-free

Solutions perfectly matched to the application can be designed using the system elements that can be combined with each other – carriages, composite guideways, track rollers and a full range of perfectly matching accessories. Curved guideways as well as a bogie carriage specially designed in-house are also part of the package. The various guideway geometries can be combined with each other without any problems should oval or other curved guideways be required.



Profiled track roller (non-locating bearing): Needle roller bearing with profiled outer ring and movable inner ring – can be used combined with guideways



Flexible range: Solid or hollow section composite guideways of aluminum with high-precision steel shafts – available with or without fixing holes



For fast and secure connection: Guideway connectors enable guideways to be quickly installed – for both straight and curved guideways

# Driven Linear Units

Transporting and positioning in feed and discharge processes are the preferred applications for compact, highly-integrated linear modules. As a supplier of systems, we offer ready-to-install complete solutions - including motors, gearbox and control systems. Every series has its special advantages. We always supply the perfect solution for every application because of our expert knowledge of the market and the close partnership with our customers from the design phase right up to initial operation, as well as the flexible configuration of our components.



Also available as a miniature actuator: Linear actuator with enclosed track rollers and toothed belt drive – inherently rigid aluminum support rail – large range of accessories

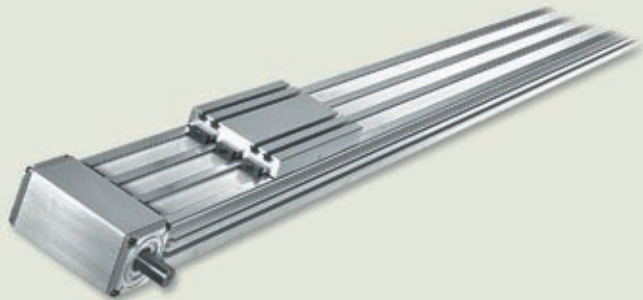

Also available as heavy-duty version: Linear actuator with enclosed monorail guidance system and triple toothed belt drive – especially suitable for horizontal and vertical mounting – large range of accessories



The customer can choose between various guidance systems (track roller and shaft guidance systems as well as linear recirculating ball bearing and guideway assemblies) and drive elements (toothed belts, spindle or linear motor drives) in accordance with the requirements of the particular application. The range is complemented by special solutions such as telescopic actuators or linear actuators with two opposing carriages as well as actuators with two or more carriages. Linear tables with or without drives are suitable if large masses must be moved in one or several axes or for supporting high torques.



Runs with high positional accuracy: Linear actuator with monorail guidance system and integrated spindle drive – spindle is covered by bellows – medium to high loads can be moved with high precision

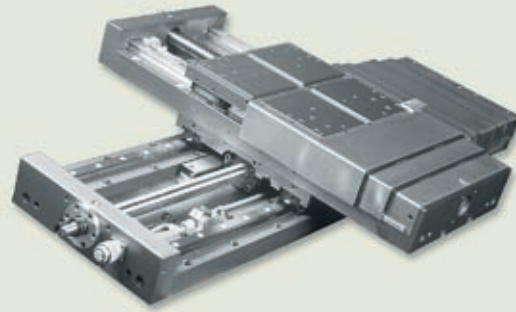

A high-precision X/Y table: Linear table with linear ball bearings or monorail guidance system – with or without drive – for use in production machinery, for example





# ems, Shafts, Actuators

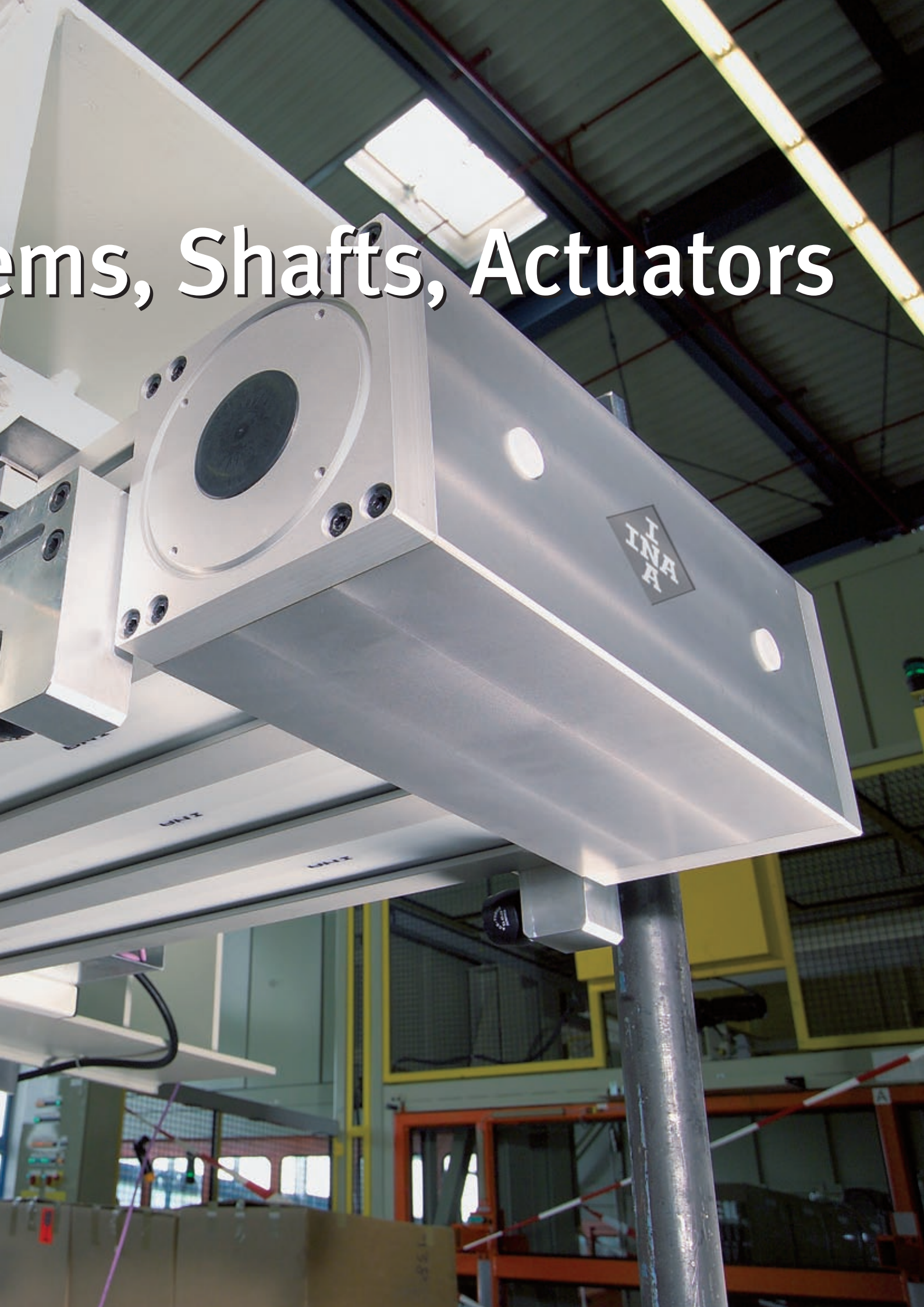



# INA Linear Technology: Comprehensive Service with In-depth Understanding of Systems

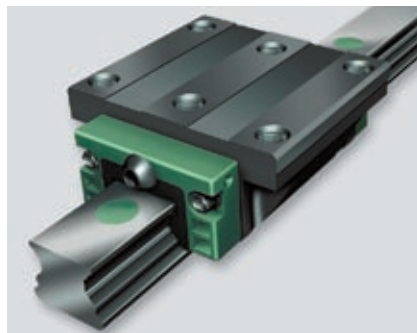
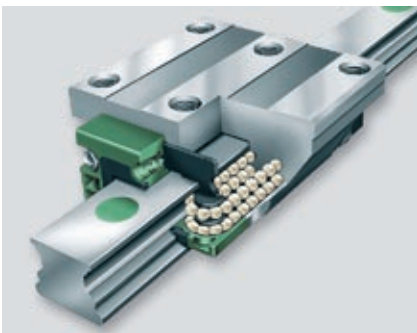

## Modern Materials

By combining various special materials, we can achieve the best possible bearing properties, even for difficult operating conditions.

- Linear recirculating ball bearing and guideway assemblies of corrosion-resistant steel suitable for use in aqueous media, heavily diluted acids, alkaline or salt solutions.
- Amagnetic monorail guidance systems – run extremely smoothly in medical technology
- Hybrid bearings with ceramic rolling elements: light, fast and durable, heat-resistant and with low lubricant consumption – for many applications in laboratories
- Metal end pieces of special steel – robust and heat resistant.

## Surface Coating

We have developed many special coatings to ensure that our standard components operate longer, without requiring maintenance and safely, even under extreme conditions. They increase the surface's resistance to corrosion and wear, improve the run-in behavior or optimize emergency running characteristics.

The selection of the coating is always dependent on the area of operation and the application. In the linear sector, we primarily use the zinc alloy Corrotect® for protection against corrosion and the thin layer chromium plating Protect for improved protection against wear.

## Service: Customized Shafts

Some shafts just aren't available in any catalogs. Or, the customer only requires a small quantity at very short notice ... An INA Quick Center is the perfect solution for all these cases: Customized shafts according to customer requirements, without a minimum order quantity and with short delivery periods.

And this is our range of services:

- Cutting, chamfering, machining shaft ends
- Heat treatment
- Simple machining steps such as turning, milling, grinding, thread cutting (radial and axial).

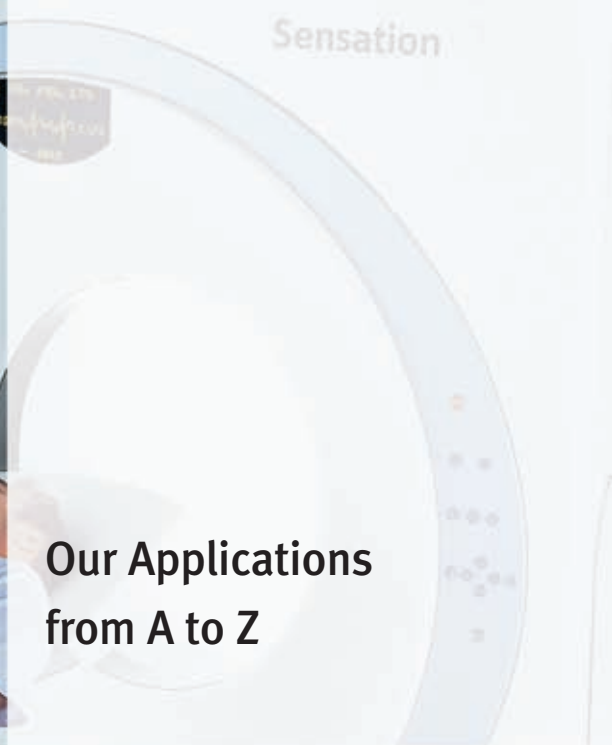

## **Our Applications from A to Z**



**Assembly and  
handling technolog  
Aviation and aerospace  
Conveying equipment  
Drives and controls  
Electronics manufacturing  
Food processing  
Industrial robots**



**Medical equipment  
Packaging machines  
Pneumatics  
Production machinery  
Rail vehicles  
Sports equipment  
Textile machinery**

**...**



**Schaeffler KG**

Geschäftsbereich Lineartechnik  
Berliner Strasse 134  
66424 Homburg/Saar (Germany)  
Internet [www.ina.com](http://www.ina.com)  
E-Mail [info.linear@schaeffler.com](mailto:info.linear@schaeffler.com)

In Germany:

Phone 0180 5003872  
Fax 0180 5003873

From Other Countries:

Phone +49 6841 701-0  
Fax +49 6841 701-2625

Every care has been taken to ensure the correctness of the information contained in this publication but no liability can be accepted for any errors or omissions. We reserve the right to make technical changes.

© Schaeffler KG · 2007, September

This publication or parts thereof may not be reproduced without our permission.